

March 2025

**NorcaTec** LLC.



*“Your Aerospace and Defense Parts Provider”*

## ***Company Overview***

***Prepared for***

***Thailand***



The information in this Presentation may contain confidential, proprietary and/or privileged information and the recipient(s) hereby agree to treat it as such. This data may not be exported, released, reprinted or disclosed without prior written approval of NorcaTec LLC.

# Executive Biographies

Name and Title	Industry Exp.	Prior Work Experience and Education
 <p><b>Samuel Gorman</b> <i>President &amp; CEO</i></p>	29 Years	<ul style="list-style-type: none"><li>▪ <b>Pratt &amp; Whitney:</b> Aftermarket Operations Management: Commercial Engines</li><li>▪ <b>Honeywell:</b> Managing Director, Integrated Supply Chain Mgmt, Aftermarket Services</li><li>▪ <b>SR Technics:</b> Aircraft Component Services, Commercial Airlines</li><li>▪ <b>AAR Corp:</b> General Manager, Defense Systems &amp; Logistics</li><li>▪ <b>University of Michigan:</b> Bachelor of Economics, Bachelor of German Language and Literature, Master of Business Administration</li></ul>
 <p><b>Allen Rosen</b> <i>Sr. Executive VP Land and Naval</i></p>	40 Years	<ul style="list-style-type: none"><li>▪ <b>NorcaTec:</b> Aftermarket Program Management for United States Government and international Aerospace and Defense markets including Land, Naval and Aircraft Platforms and Systems</li><li>▪ <b>Hobart and William Smith Colleges:</b> Bachelor of Economics</li></ul>
 <p><b>Thomas Duncan</b> <i>Executive VP – Sales, Marketing and Business Development</i></p>	41 Years	<ul style="list-style-type: none"><li>▪ <b>Sikorsky:</b> Aftermarket Program Management</li><li>▪ <b>Lycoming Engines:</b> Commercial and Military Turbine Engine Supply Chain Management</li><li>▪ <b>Honeywell Aerospace:</b> Sales and Marketing for global defense markets</li><li>▪ <b>M International:</b> Worldwide MRO and Spares Sales/Depot Maint Support</li><li>▪ <b>Southern Connecticut State University:</b> Bachelor of Science</li></ul>

# We are...

- a leading **defense industry** material supply chain company
- specializing in **US manufactured equipment** and platforms
- focused on **aircraft** and **armored vehicle** support
- oriented towards servicing **foreign military customers** and OEMs
- delivering distribution, logistics and **aftermarket** services solutions
- **operating globally** through large network of agents and representatives
- owned and funded by a small, private industrial group
- a **registered small business** on SAM (System for Award Management)
- committed to transparent business practices, the highest ethical standards, and **FCPA** compliance through TRACE International certification



# Our core competencies include...

- accessing **global markets** for sourcing and selling military products
- strong capability to **import and export** controlled defense articles
- proficiency in fulfilling **hard-to-find material** requirements
- effective material planning solutions to support **stocking distribution** models
- providing world-class **customer service** and relationship management
- **flexibility** to custom-tailor solutions to meet customer requirements
- procurement through **experienced** sourcing and purchasing teams
- performing **light manufacturing** including assembly and test
- technical and manufacturing engineering services for armored vehicles including reverse engineering and **build-to-print**



# Major Military Divisions

**NorcaTec** LLC.



Distributor, reseller and broker of:

- Aircraft engine and airframe systems components for fixed and rotary wing aircraft
- Armored tracked/wheeled vehicle spare parts
- Naval gun new production components, spare service parts and kits for sustainment
- Equipment for legacy air defense systems
- Licensed manufacturing of obsolete aircraft engine components



**NAPCO International LLC.**

A Division of  
**NorcaTec** LLC.

- Focused exclusively on the sustainment of US-manufactured tracked and wheeled military vehicles
- Specializing in procurement, engineering, project management, light manufacturing and materials management
- Partnering with large US-based OEMs to support the new production, upgrade and reset of legacy equipment



# Specialty Divisions



- Pennsylvania-based build-to-print company acquired in 2022 with expertise in supporting highly engineered and specialized US Navy specifications
- Specialties include:
  - Junction & Distribution Boxes
  - Encapsulated Electronics
  - Connector Assemblies
  - Control Panels
  - RF Cables
  - Bus Bars

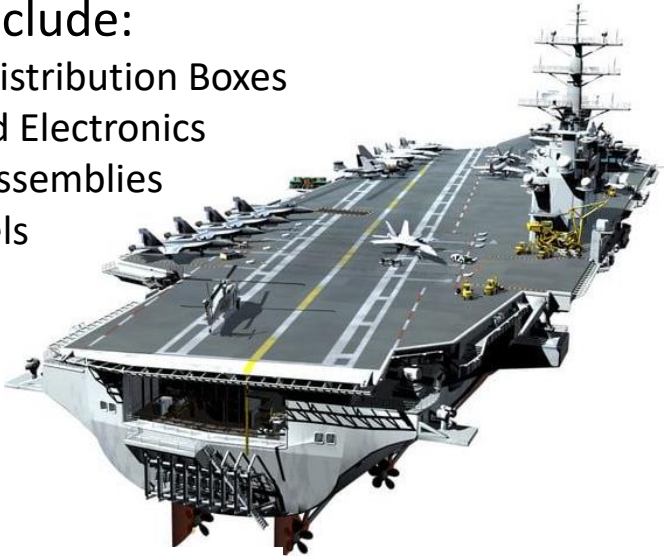

- Providing electronic and electro-mechanical components to overseas commercial, defense, and space customers for over 50 years
- US/Canadian supplier base covers broad range of electronic components including switches, displays, connectors, semiconductors, circuit breakers, diodes, power supplies and more
- Strong ability to source obsolete items
- Product offering exceeds 3 million PNs



# Corporate History



**1918**

**Northwestern Auto Parts Company** (NAPCO) Intl. founded with motto: "For that hard to get part"

**1946**

**Norca Corp** founded with Manhattan offices in Empire State Building



**1958**

Norca Machinery establishes H&R Parts division to supply material to US Government and DOD



**1991**

NAPCO Intl. begins efforts supporting BAE international programs



**1995**

Norca Machinery acquires aerospace electronics division



**2001**

**NorcaTec acquires a privatized NAPCO Intl.** Awarded IPV as Raytheon subcontractor



**2014 - 2022**

Exclusive T53 Engine Master Distributor  
Exclusive TFE731-2A-2A Engine Distributor  
Launched SBSA PMO  
P&W Licensing with Kaman/Extex



**1940**

NAPCO Intl. begins servicing US Department of Defense and international military markets



**1953**

NAPCO Intl. listed and became publicly traded as NAPCO Industries

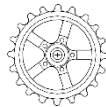

**1956**

Norca Corp expands to add Norca Machinery



**1962**

Norca Machinery signs exclusive Goodyear export distribution agreement for tank track shoes and other armored vehicle parts

**1996**

Norca Machinery renamed NorcaTec LLC resulting from expanded scope



**2010**

P&W awards NorcaTec exclusive license to distrib. JT8D-9 engine parts to Japan MOD



**2011** **TEXTRON**

NAPCO Intl. licensed by Textron Marine and Land Systems for Cadillac Gage family of armored vehicles through 2016

*Providing over 100 years of customer service and innovation*



# Operating Locations



60,000 sqft Central Warehouse and Distribution Facility Brooklyn Park, MN



Corporate HQ Garden City, Long Island, NY



Orlotronics Navy Prog Mgmt Norristown, PA

*Operating from 3 locations to service our global customer base*

# Commitment to Quality









- Quality Management System (QMS)
  - ISO Certified since 2004 - Currently at ISO 9001:2015
  - AS9120 Certified since April 2016
  - AS9100 Certified since July 2021
  - BSI certified as independent auditor and registrar
- QMS Audited and deemed acceptable by DCMA
- Driving continuous process improvement
- Fully digitized archive of product certificates for traceability backed up daily
- Detection and Avoidance of Electronic Counterfeit Parts DFAR compliance
- Manage over 50,000 Microfilm and electronic drawings
- Access to 22,000 qualified historical vendors



*Quality is our #1 priority*

# Government and Regulatory Compliance

NorcaTec maintains a number of registrations and certifications to assure regulatory compliance, organizational capability, and business continuity:

-  US Department of State Manufacturer/Exporter Registration (Reg M-3374)
-  US Department of State Brokers Registration (Reg K-6738)
-  US Department of Justice Registered Importer of USML Articles (Reg A-27-296-0911)
-  US Department of Commerce Registered Exporter
-  Cybersecurity Maturity Model Certification (CMMC) In Progress
-  TRACE Certified: Comply to worldwide anti-bribery standards (Rep ID: TC4142-2402)
-  On-Staff Export Compliance Officer
-  SBA Registered Small Business (ID: NSM9HXQM5L3)



# Cybersecurity Maturity Model Certification (CMMC)

NorcaTec has been heavily investing in CMMC since 2019 with compliance remaining a company priority with dedicated resources

- 🔒 Strategic Initiative Driven by Leadership Team
- 🔒 Enterprise Imperative to Assure Business Continuity
- 🔒 Assurance of Support for Major Military Customers

Numerous systems and tools have been deployed to assure compliance:

- **FutureFeed:** Platform to create and manage a structured cybersecurity program based on NIST SP 800-171
- **PreVeil:** End-to-end encryption for storage and transmission of CUI. CUI enclave in Preveil AWS Government cloud environment for storage of CUI for ITAR and CMMC compliance.
- **Intune/Microsoft Endpoint Manager:** Used for centralized authentication for local workstations/laptops as well as management of baseline configurations such as BitLocker and security policies for CUI users.
- **Bitlocker:** Enforced encryption of data at rest for all workstations/laptops of CUI staff. Policy is enforced through Microsoft Endpoint Manager/Intune.
- **Federal DUO:** Federal DUO is configured to automatically install for all CUI staff via Microsoft Endpoint Manager/Intune. This is used to require MFA at the local workstation level. Users in the CUI groups automatically sync to DUO and enforcement would be required upon onboarding.

*Aiming for full compliance & certification by end of 2025*



**FutureFeed**



**THREATLOCKER**



# Revenue Segmentation (2024)

Sales by Region

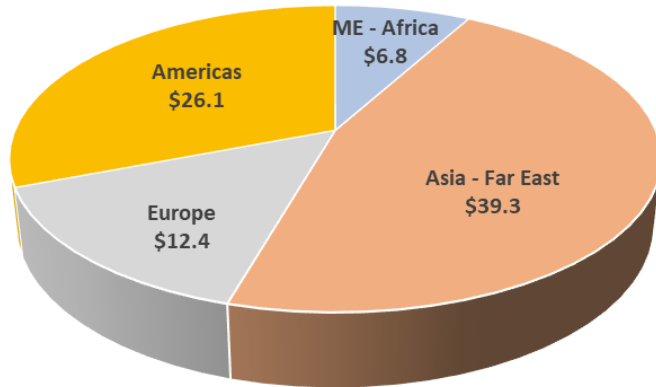

Sales by Domain

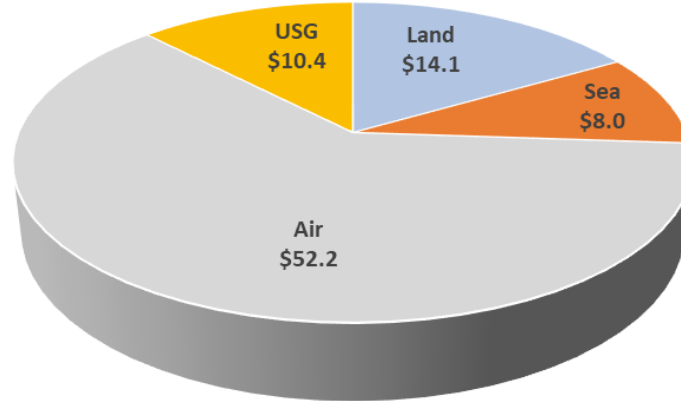

Sales by Country

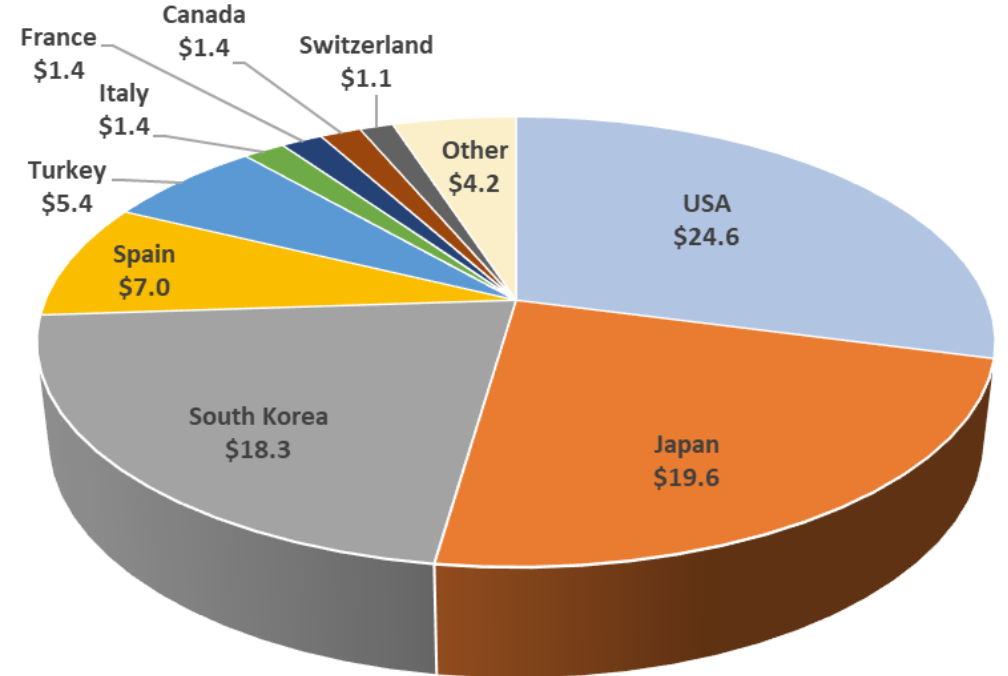

*Approximately 70% of revenues generated internationally*

# Active Global Sales Territory



*Supporting customers in  
over 60 countries worldwide*



# Supported Platforms: Tactical Wheeled

- 1/4 ton: M38, M38A1, M151A2, CJ Series Jeep
- 3/4 ton: M37, CUCCV, M715
- 1 1/4 ton: M998 (HMMWV Family of Vehicles)
- Truck 2 1/2 ton: M34, M35, M35A1, M35A2, M36, M211, M602
- Truck 5 ton: M52, M54, M55, M62, M543, M8XX and M93X
- Trailers: Talbert all makes and models



# Tracked Platforms Supported



Abrams M1 MBT



Bradley M2

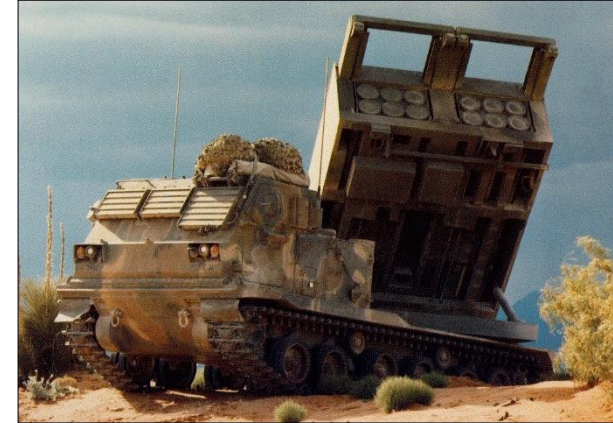

M270 MLRS



M88 Recovery Vehicle



M109 Self Propelled Howitzer



M60 (Patton) MBT

# Tracked Platforms Supported



Abrams M1 MBT



M113 APC

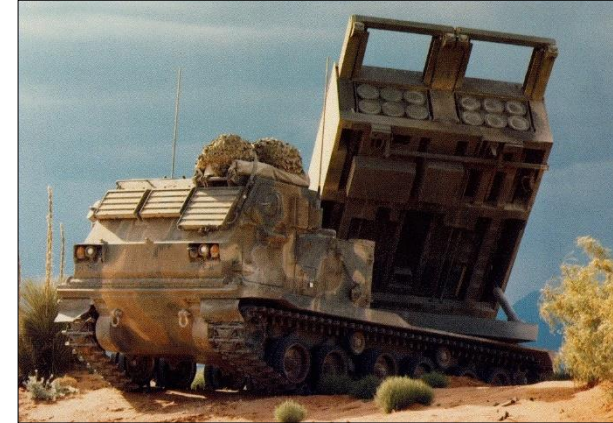

M270 MLRS



M88 Recovery Vehicle



M109 Self Propelled Howitzer



M60 (Patton) MBT

# Major BAE Vehicle Platforms Supported



AAV-7



M2 Bradley



M270 MLRS



M88 Hercules



M109 SPH



M113 APC

# Supported Platforms: Armored Tracked/Wheeled

- Armored Vehicles: M113 Series, AIFV, V150, M1117 ASV, LAV
- Self Propelled Howitzers: M107, M108, M109, M110, M578
- Main Battle Tanks: M1, M1A1/2, M24, M41, M47, M48, M60, M728
- Amphibious Assault Vehicles: LVTP-5, LVTP-7, AAV-7
- Infantry Fighting Vehicles: M2/M3 Bradley
- Miscellaneous Vehicles: M88A1, M88A2 HERCULES, M9 ACE



# Loc Performance

Loc Performance provides track systems, mechanical systems, armor products, fabricated structures, and rubberized products for military, agricultural, and construction applications. With proven capabilities in product design and development in their 1,750,000 square feet of manufacturing space

- Military Track Systems
- Final Drive
- Suspension Systems
- Power Take-Off
- Armor Doors
- Turret Hatches
- Underbelly Armor



# Track Assembly and Component Support



1940- First Track is produced in St. Mary's Ohio.  
1962- NorcaTec becomes export distributor.



2007-Products Will Continue to Carry Goodyear Brand While  
Company Legal Name Changes to "Veyance Technologies, Inc."



2015-German-based Continental AG agreed to buy Veyance  
Technologies Inc. from investment company Carlyle Group LP



2021-Loc Performance ("Loc") completed the  
acquisition of Continental's St. Marys, Ohio facility.



*Over 60-Years of ongoing support for  
vehicle Track worldwide*



# CE Niehoff

CEN Alternators are on a variety of Light (<10T), Medium (10-20T) and Heavy Tonnage Vehicles (>20T)

- Infantry Fighting Vehicles
- Tanks
- Ground Vehicles (including Amphibious)
- Armored Support Vehicles
  - Personnel Carriers
  - Resupply
  - Combat Engineer
  - Recovery
  - Ambulances
  - Command & Control



# CE Niehoff

## Alternator Features

- Brushless
- Stationary windings
- Long life bearings/ labyrinth seals
- High efficiency
- High reliability
- High output at low idle
- Extreme environment capable
- Air cooled
- Field serviceable
- Customizable
- Multiple mounting options
- Advanced regulator technology
  - Lead Acid & Li-Ion

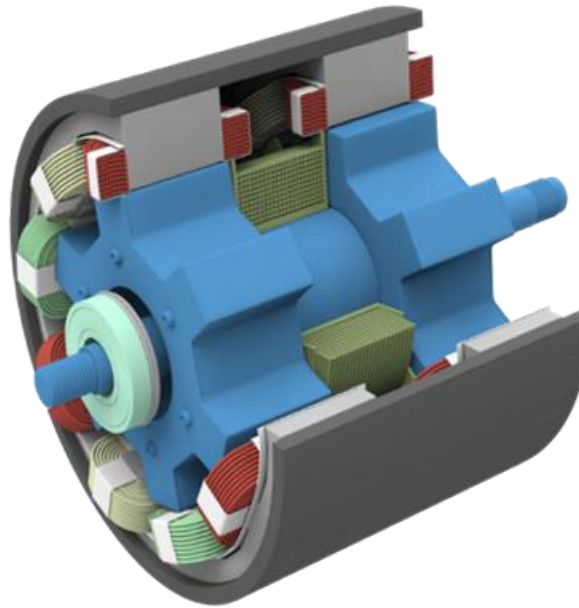







# Authorized Distribution: Tactical Wheeled



**MERITOR**

**AXLETECH**



-  Transfer Cases
-  Gearbox and Power Take-offs
-  Transfer Cases
-  Axles
-  Brakes
-  Drivelines
-  Auxiliary Transmissions

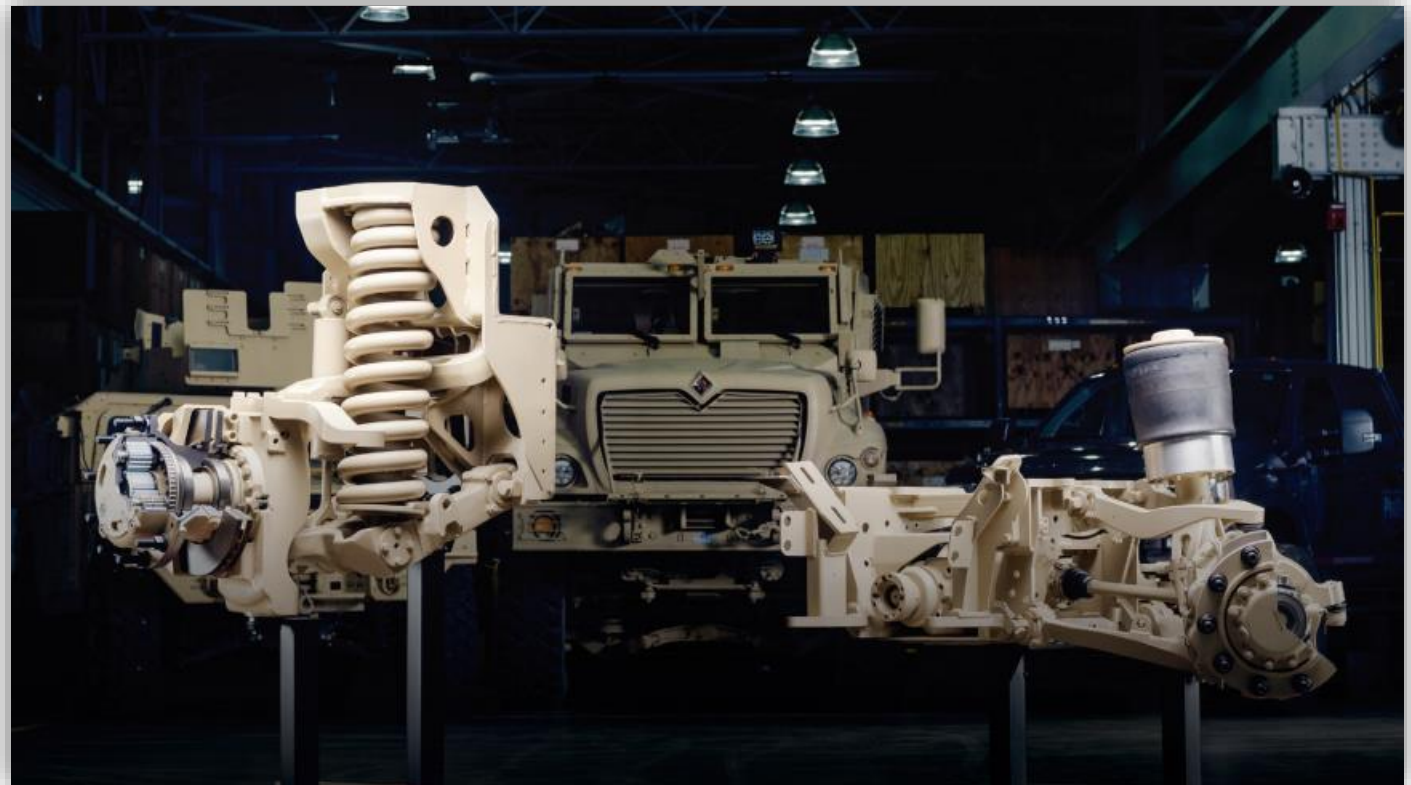





# Meritor (Cummins)

- Meritor – a leading global supplier of drivetrain, mobility, braking, aftermarket powertrain solutions for military vehicles since World War II
- Meritor drivetrain solutions are included in most wheeled tactical vehicles manufactured in the US.

- Axles
- Brakes
- Carriers
- Drivelines



-  Gearboxes
-  Suspensions
-  Tire Inflation Systems
-  Transfer Cases



# Meritor (Cummins) – Parts

Meritor® offers high-quality aftermarket parts engineered to exact OEM specifications. Meritor parts represent proven performance and lasting value for brand new vehicles and legacy vehicles. These aftermarket parts meet performance expectations on all makes of vehicles and deliver a proven level of quality, performance and value and are only available through authorized Meritor Distributors.

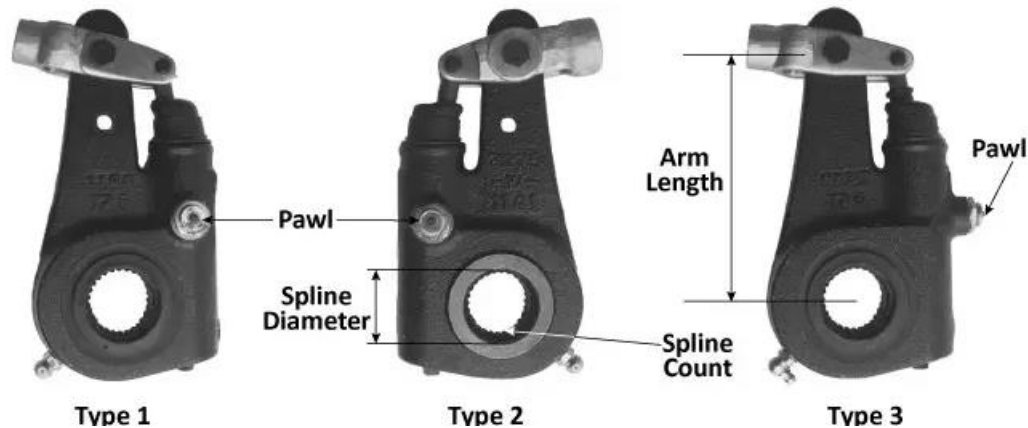

# Supported Platforms: Naval and Air Defense

## Naval Supply Capability

- Mark 45 (MK45) Gun
- OTO Melara 76mm Gun
- Phalanx CIWS
- Radar/Sonar/Electronics
- Assault Amphibious Vehicle (AAV)

## Missiles and Air Defense

- HAWK
- Patriot
- Nike
- TOW



# BAE MK45 Naval Gun Support

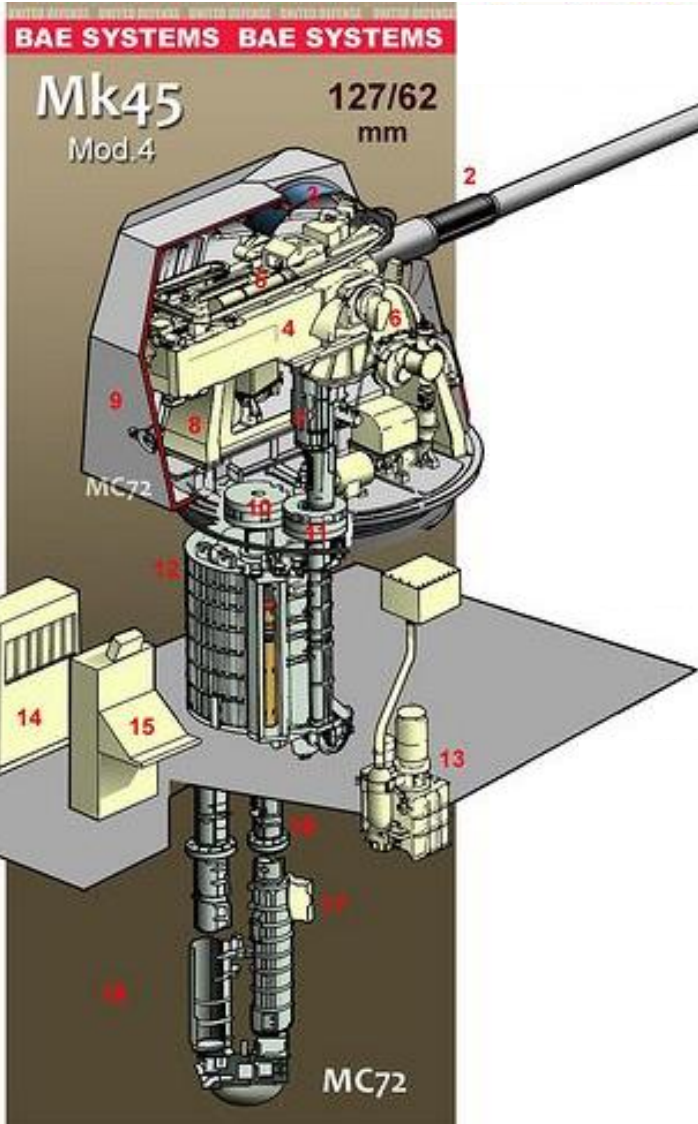

## Major Systems

- Lower Hoist
- Hydraulic Unit
- Gun Shield
- Lower Accumulator System

## Major Components/Kits

- Electric and Hydraulic Motors
- Resolvers
- Servo Valves
- Hoist Chain
- Complete Kits for Maintenance



*Providing over  
1800 line items  
in support of the  
system*

# Distribution and Manufacturing Capability

## Representative Products Traded

Aviation



Landing Gear



Auxiliary Power



Turbine Wheels



Fuel Controls



Hydraulics



Electrical



Hardware/Fasteners



Compressors

Ground



Gearboxes



Final Drives



Track



Suspension

Naval



Servovalves



Motors



Resolvers

## Sample In-House Build to Print



Angle Drive Unit



Support Roller



Power Take-off

- In-house manufacturing and test capability for complex subsystems
- Products built to OEM/USG technical and quality specifications
- Extensive technical library and supply chain
- Flexible workshop and cross-trained technical staff

*Supporting a wide range of products for the A&D Market*

# Track Quality and Dependability

- Widely recognized as the industry leader in track manufacture
- OEM approved and preferred (BAE, GDLS)
- Superior Reliability and MTBF
- Differentiation through proprietary Rubber Compound Development and Testing Expertise
  - Fully Qualified to MIL-DTL-11891
  - Listed on Qualified Parts List (QPL) 11891
- Only source qualified for all US track configurations
- Only private industry source on US DOD primary track configurations:
  - T158 (M1 Abrams MBT)
  - T161 (Bradley, M109A7, AMPV)
- Exceptional standard for After Market Support and Service



# Supported Platforms: Rotary Wing



S-92  
SH-60, UH-60  
S76, S61  
SH-3, HH-3  
S70



AH-64 Apache  
CH-47 Chinook  
AH-6I



Huey UH-1  
Bell 205, 206, 212, 412  
AH-1S  
OH-58



MD500 Series



# Supported Platforms: Fixed Wing



F-15 Eagle

F-16 Falcon

T-37 Tweet

F-5 Tiger

F/A-18 Hornet

C-130 Hercules

205 Super Skywagon\*

A-4 Skyhawk

KC-130

F-4E Phantom II

P-3 Orion

KC-135 Stratotanker



*\*Includes 206 and 207 Super Skywagon*



# Supported Platforms: Aero Engines



J79  
J85  
T58  
T64  
T700  
F110  
F404



JT8D  
F100  
JT15D  
PT6A-20



T56  
M250



T53  
T55  
TFE731

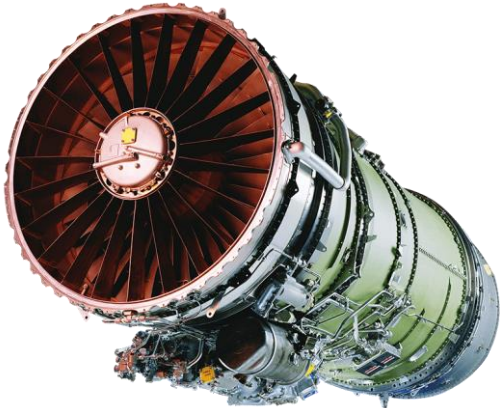
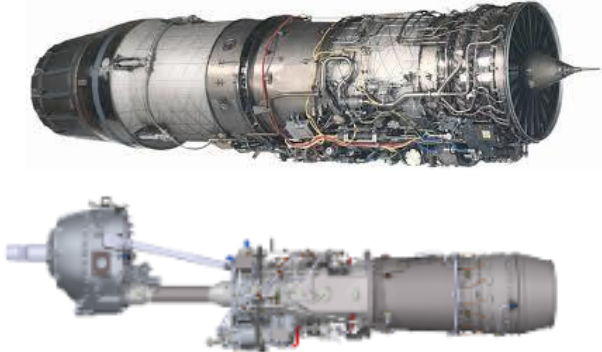

*Capability to support engines from all major engine manufacturers*



## H-60 STRAIGHT PIPE EXHAUST SYSTEM

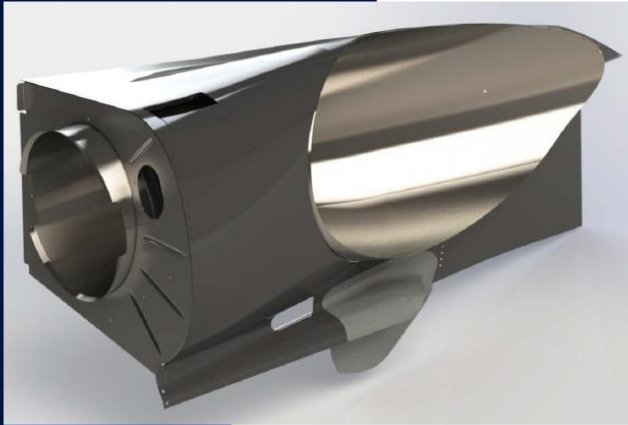

FAA PMA Approved

PMA No. PQ2112NM - 22  
Part # AM70308-03100-043 / 044  
Exhaust Assembly



### Key Benefits:

- Reduction in aircraft weight of 172 lbs\* from HIRSS
- Reduction in engine exhaust losses from HIRSS

## H-60 / S-70 Inlet Barrier Filter System

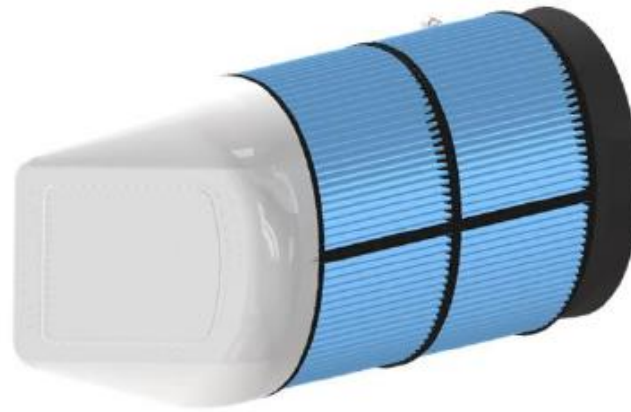

# Aerometals



# Program Overview: T53 Case Study

- T53 Authorized Distributor since 2014**
  - Authorized Service Center network offered little flexibility
  - Honeywell material fill rates below 60%
  - HON policy not to plan or stock required material
  - Un-forecasted demand made distributors reluctant to stock
- Limited Exclusivity beginning 2016-2018**
- Exclusive Master Distributor begins 2019**
  - Heavy inventory investment to support UH-1/AH-1 fleets
  - Stocking over 500 OEM factory new PNs in inventory
  - Reduced material cost through volume purchases (MOQ)
  - Fill rates to Authorized Service Centers now exceed 90%
  - Overhaul turn around times decreased across MRO segment
  - Same-day deliveries offered to support work stoppages
  - Enhanced service levels to international operators
  - Currently have over \$22mUSD on order with HON for stocking

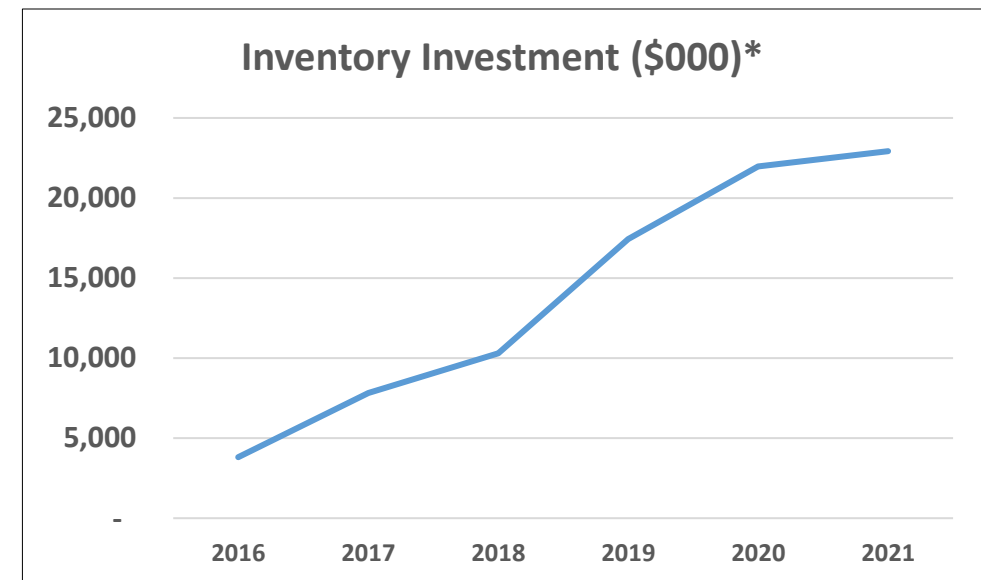

\*Year-end gross inventory position

# Major Customers

## OEM/MRO

**BAE SYSTEMS**

**GENERAL DYNAMICS**  
Land Systems

**TEXTRON** Marine & Land Systems //  
TEXTRON Systems

**HYUNDAI**  
**WIA**

**JSW**  
THE JAPAN STEEL WORKS, LTD.

**PIAGGIO**  
AEROSPACE

**Kawasaki**

**KAI** KOREA AEROSPACE  
INDUSTRIES, LTD.

**Elbit Systems™**

**RUAG**



**ITP Aero**

**Hanwha**

**OZARK  
AEROWORKS**

AN EAGLE PARTNER

## Government/Military

-  Defense Logistics Agency
-  JMOD/Japan Defense Agency
-  Turkish Ministry of Defense
-  Egyptian Armored Authority
-  Pakistan Armed Forces
-  Chilean Air Force
-  Algerian People's National Army
-  Spanish Air Force
-  Tunisian Armed Forces
-  Brazilian Air Force
-  Finnish Defence Forces
-  Malaysian Armed Forces
-  Israeli Ministry of Defense



# Key Product and Service Lines Represented

**Honeywell**



# Major Suppliers Supported and Partners



# Contact Us



## Samuel Gorman

President & CEO  
Direct : +1.516.640.3122  
Email: sgorman@norcatec.com

## Allen Rosen

Sr. EVP Land & Naval Systems  
Direct: +1.516.640.3102  
Email: arosen@norcatec.com

## Tom Duncan

EVP Sales, Marketing and BD  
Direct: +1.516.640.3124  
Email: duncan@norcatec.com

## NorcaTec LLC

Corporate Headquarters  
100 Garden City Plaza  
Suite 530  
Garden City, NY 11530  
United States of America

Central Distribution Center  
9200 75th Av. N. Suite 140  
Brooklyn Park, MN 55428  
United States of America

[www.norcatec.com](http://www.norcatec.com)

Telephone: +1.516.222.7070  
Fax: +1.516.222.8811  
CAGE Code: 9A148

